

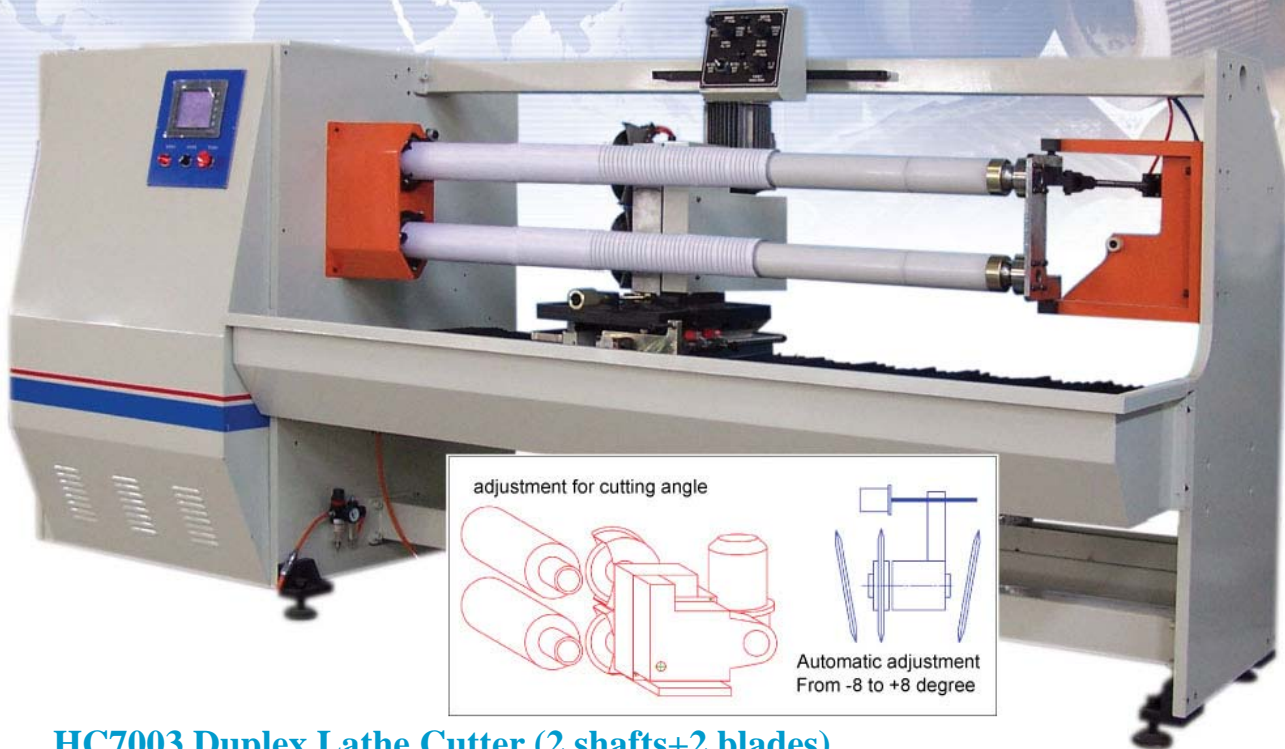

Lathe Cutter



HC7003 Duplex Lathe Cutter (2 shafts+2 blades)

Application: Suitable for cutting various adhesive tapes.

(2 shafts cutting a time, double on production capacity)

Specification: Machine Width: 1.0M/1.3M/1.6M Max. Cutting O.D: Ø160mm
Cutting Core O.D: Ø3" Min. Cutting Width: 3mm

Feature:

1. Width setting is controlled by servo motor with ball screw and guide rails to make accuracy movement.
2. All functions are operated under LCD touch panel control, which is operator friendly and easy for data setting.
3. Central control system is PLC unit, it can cut various sizes on one log roll by changing modes automatically.
4. Knife feeding is controlled by hydraulic system, the cutting speed is adjustable in high/low.
5. Equipped with knife angle manual adjustment, cutting angle can be changed from -8 to +8 degree automatically for making roll surface smoothly.

Optional Parts:

1. Equipped with knife angle auto adjustment, cutting angle can be changed from -8 to +8 degree automatically for making roll surface smoothly.
2. Knife feeding is controlled by servo motor.
3. Other Size Cutting Shaft: It can be made as per the required core I.D.
4. Cutting Supporter: For supporting log roll when cutting core below 38mm.
5. Safety Cover: To protect operator during the production.

(For reference only)



Hengcheng Machinery Co., Ltd.

Manual and Automatic Single/Double Knife Roll Slitters and Slitter/Rewinders

E-mail: info@slitting-rewinder.com

URL: www.slitting-rewinder.com

Tel: +86-512-53100920

Fax: +86-512-53100720